XII. Mathematics, Grade 6

Grade 6 Mathematics Test

The spring 2014 grade 6 Mathematics test was based on standards in the five domains for grade 6 in the *Massachusetts Curriculum Framework for Mathematics* (March 2011). The grade 6 standards can be found on pages 53–58 in the *Framework*, and the five domains are listed below.

- Ratios and Proportional Relationships
- The Number System
- Expressions and Equations
- Geometry
- Statistics and Probability

The *Massachusetts Curriculum Framework for Mathematics* is available on the Department website at www.doe.mass.edu/frameworks/current.html.

Mathematics test results are reported under five MCAS reporting categories, which are identical to the five framework domains listed above.

The tables at the conclusion of this chapter indicate each released and unreleased common item's reporting category and the framework standard it assesses. The correct answers for released multiple-choice and short-answer questions are also displayed in the released item table.

Test Sessions

The grade 6 Mathematics test included two separate test sessions. Each session included multiple-choice, short-answer, and open-response questions. Approximately half of the common test items are shown on the following pages as they appeared in test booklets.

Reference Materials and Tools

Each student taking the grade 6 Mathematics test was provided with a plastic ruler and a grade 6 Mathematics Reference Sheet. A copy of the reference sheet follows the final question in this chapter. An image of the ruler is not reproduced in this publication.

The use of bilingual word-to-word dictionaries was allowed for current and former English language learner students only, during both Mathematics test sessions. No calculators, other reference tools, or materials were allowed.

Grade 6 Mathematics

SESSION 1

You may use your reference sheet and MCAS ruler during this session.

*You may **not** use a calculator during this session.*



DIRECTIONS

This session contains ten multiple-choice questions, one short-answer question, and two open-response questions. Mark your answers to these questions in the spaces provided in your Student Answer Booklet.

- 1 Gwen studies for 1.5 hours every night. What is the total number of hours Gwen studies for 5 nights?
- A. 4.5 hours
 - B. 5.5 hours
 - C. 6.5 hours
 - D. 7.5 hours
- 2 A disk in the shape of a circle has a diameter of 64 millimeters. What is the radius of the disk?
- A. 8 millimeters
 - B. 32 millimeters
 - C. 64 millimeters
 - D. 128 millimeters
- 3 The total amount of money collected by a store for sweatshirt sales was \$10,000. Each sweatshirt sold for \$40. What was the total number of sweatshirts sold by the store?
- A. 100
 - B. 220
 - C. 250
 - D. 400

- 4 Jeanie has a goal to run a total of 800 laps around her school's track this year. Her plan is to run exactly 4 laps each day.

Which of the following expressions represents the total number of laps Jeanie will have left to run after d days?

- A. $800 - 4d$
- B. $800d - 4$
- C. $4d - 800$
- D. $4 - 800d$

- 5 The students at Riverside School collected 100,000 pennies to buy new library books. Which of the following is equivalent to 100,000?

- A. 10^3
- B. 10^4
- C. 10^5
- D. 10^6

Question 6 is a short-answer question. Write your answer to this question in the box provided in your Student Answer Booklet. Do not write your answer in this test booklet. You may do your figuring in the test booklet.

- 6 What value of x makes the equation below true?

$$4x = 24$$

Question 7 is an open-response question.

- **BE SURE TO ANSWER AND LABEL ALL PARTS OF THE QUESTION.**
- **Show all your work (diagrams, tables, or computations) in your Student Answer Booklet.**
- **If you do the work in your head, explain in writing how you did the work.**

Write your answer to question 7 in the space provided in your Student Answer Booklet.

- 7** A dairy farmer uses two trucks to deliver milk. The two trucks use different kinds of fuel. Truck A uses gasoline and Truck B uses diesel. The table below shows the distance, in miles, that each truck can travel per gallon of fuel.

Miles Traveled per Gallon of Fuel

Gallons of Fuel	Truck A (Gasoline)	Truck B (Diesel)
1	8 miles	12 miles
2	16 miles	24 miles
3	24 miles	36 miles
4	? miles	48 miles
5	40 miles	60 miles

- a. Based on the table, what is the total number of miles Truck A can travel using 4 gallons of gasoline? Show or explain how you got your answer.
- b. Based on the table, what is the total number of gallons of diesel Truck B will use to travel 132 miles? Show or explain how you got your answer.
- c. Gasoline costs \$4 per gallon and diesel costs \$5 per gallon. Which truck will have a lower fuel cost for a 24-mile trip? Show or explain how you got your answer.

Mark your answers to multiple-choice questions 8 through 12 in the spaces provided in your Student Answer Booklet. Do not write your answers in this test booklet. You may do your figuring in the test booklet.

- 8 Karla wrote the equation shown below.

$$x \div 6 = 12$$

What value of x makes Karla's equation true?

- A. 2
- B. 6
- C. 36
- D. 72

- 9 A net was folded to make the box shown below.

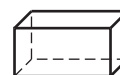

Which of the following nets could be folded along the dotted lines to make this box?

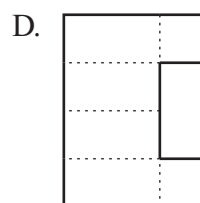
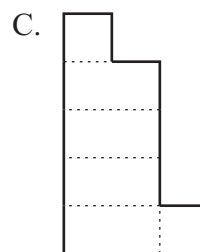
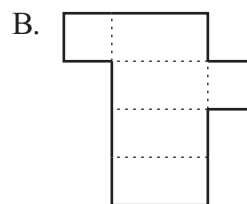

10 Which of the following mixed numbers has a value between $\frac{10}{3}$ and $\frac{11}{3}$?

A. $3\frac{1}{2}$

B. $3\frac{1}{4}$

C. $3\frac{3}{4}$

D. $3\frac{1}{8}$

- 11 The cost of renting a bicycle from Dan’s Bike Shop is \$2 for 1 hour plus \$1 for each additional hour of rental time.

Which of the following graphs shows the cost, in dollars, of renting a bicycle from Dan’s Bike Shop for 1, 2, 3, and 4 hours?

A. **Bicycle Rental Cost**

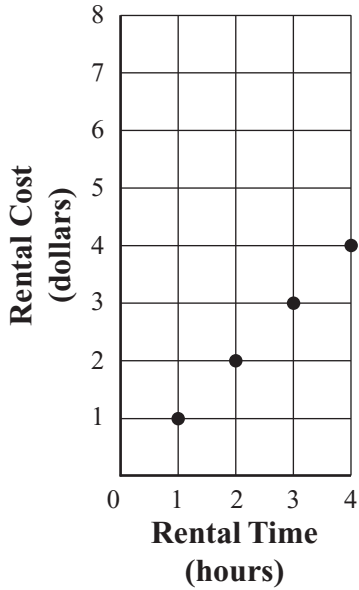

C. **Bicycle Rental Cost**

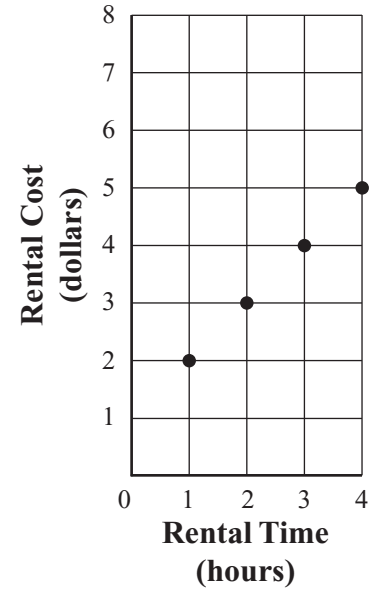

B. **Bicycle Rental Cost**

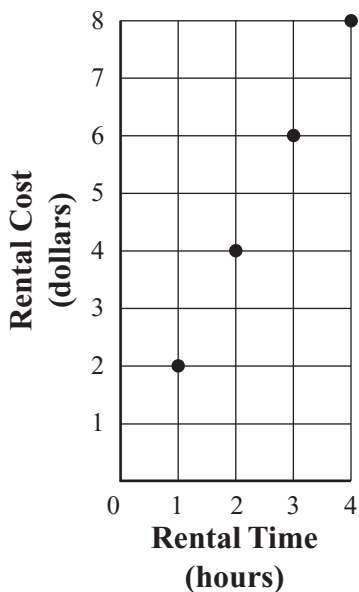

D. **Bicycle Rental Cost**

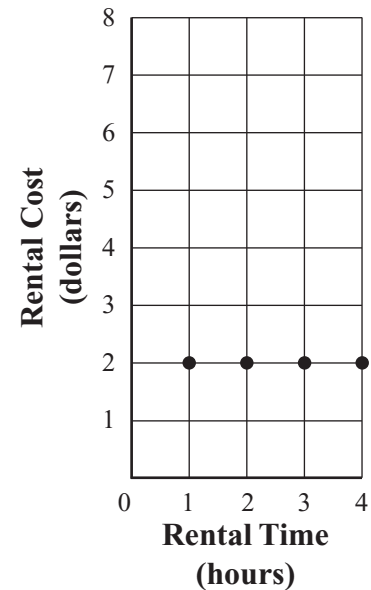

- 12 There were 5 players in a game.
- 2 players scored 40 points **each**
 - 2 players scored 50 points **each**
 - 1 player scored 90 points

What was the mean number of points scored by the 5 players in the game?

- A. 36
- B. 50
- C. 54
- D. 60

Question 13 is an open-response question.

- BE SURE TO ANSWER AND LABEL ALL PARTS OF THE QUESTION.
- Show all your work (diagrams, tables, or computations) in your Student Answer Booklet.
- If you do the work in your head, explain in writing how you did the work.

Write your answer to question 13 in the space provided in your Student Answer Booklet.

- 13 Marissa made the circle graph below to show how she spends her exercise time each week.

**Marissa’s Exercise Time
Each Week**

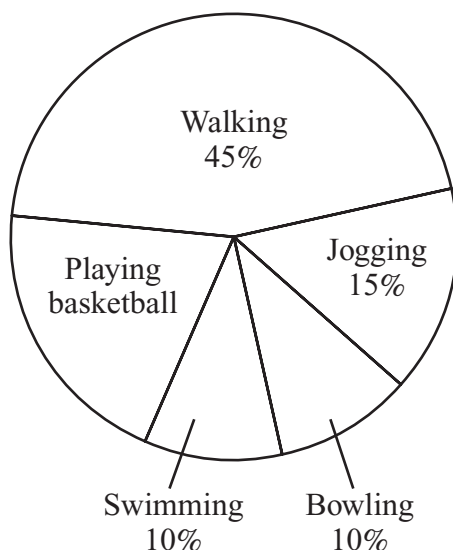

- a. What percent of her exercise time does Marissa spend playing basketball? Show or explain how you got your answer.
- b. Marissa spent a total of 240 minutes exercising last week. How many minutes did she spend **walking**? Show or explain how you got your answer.
- c. Marissa will spend a total of 180 minutes exercising this week. Based on the graph, how many fewer minutes will she spend walking this week than she did last week? Show or explain how you got your answer.

Grade 6 Mathematics

SESSION 2

You may use your reference sheet and MCAS ruler during this session.
You may **not** use a calculator during this session.



DIRECTIONS

This session contains six multiple-choice questions and two short-answer questions. Mark your answers to these questions in the spaces provided in your Student Answer Booklet.

- 14 The expression 5^3 represents the volume, in cubic centimeters, of a cube that has an edge length of 5 centimeters.

What is the volume of the cube?

- A. 15 cubic centimeters
- B. 25 cubic centimeters
- C. 125 cubic centimeters
- D. 625 cubic centimeters

- 15 Which of the following is equivalent to the expression below?

$$6m + 3$$

- A. $2(3m + 3)$
- B. $3(2m + 1)$
- C. $3(2m + 3)$
- D. $6(m + 3)$

- 16 Which of the following numbers is **not** a solution of the inequality below?

$$x > -5$$

- A. 0
- B. -2
- C. 5
- D. -10

- 17 Which of the following is equivalent to the expression below?

$$3\frac{2}{3} \div \frac{2}{3}$$

- A. $5\frac{1}{2}$
- B. 4
- C. 3
- D. $2\frac{4}{9}$

Questions 18 and 19 are short-answer questions. Write your answers to these questions in the boxes provided in your Student Answer Booklet. Do not write your answers in this test booklet. You may do your figuring in the test booklet.

- 18 The temperature on Saturday was -4 degrees Fahrenheit ($^{\circ}\text{F}$). The temperature on Sunday was 9 degrees warmer than the temperature on Saturday. What was the temperature, in degrees Fahrenheit, on Sunday?

- 19 A rectangular prism and its dimensions are shown below.

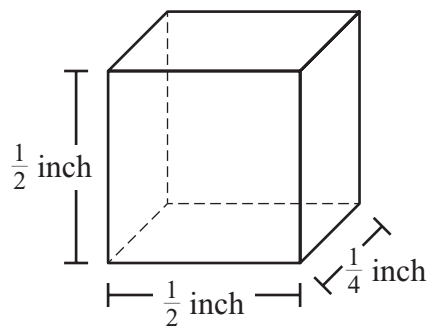

What is the volume, in cubic inches, of the prism?

Mark your answers to multiple-choice questions 20 and 21 in the spaces provided in your Student Answer Booklet. Do not write your answers in this test booklet. You may do your figuring in the test booklet.

20 Sydney ran 400 meters in 1 minute and 20 seconds. What was Sydney’s average rate in meters per second?

- A. $\frac{1}{5}$
- B. 3
- C. $3\frac{1}{3}$
- D. 5

21 Kwame drew the triangle shown in the diagram below.

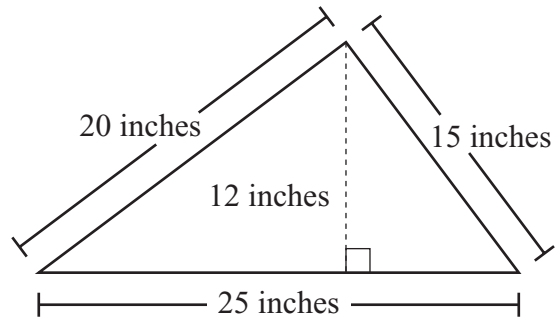

Based on the dimensions in the diagram, what is the area of Kwame’s triangle?

- A. 150 square inches
- B. 250 square inches
- C. 300 square inches
- D. 375 square inches

PERIMETER FORMULAS

perimeter = distance around

square $P = 4s$

rectangle $P = 2b + 2h$

OR

$P = 2l + 2w$

triangle $P = a + b + c$

AREA FORMULAS

square $A = s \times s$

rectangle $A = bh$

OR

$A = lw$

parallelogram $A = bh$

triangle $A = \frac{1}{2}bh$

circle $A = \pi r^2$

VOLUME FORMULAS

rectangular prism $V = lwh$

cube $V = s \times s \times s$

(s = length of an edge)

CIRCLE FORMULAS

$C = 2\pi r$

OR

$C = \pi d$

$A = \pi r^2$

Grade 6 Mathematics
Spring 2014 Released Items:
Reporting Categories, Standards, and Correct Answers*

Item No.	Page No.	Reporting Category	Standard	Correct Answer (MC/SA)*
1	186	<i>The Number System</i>	NS.3	D
2	186	<i>Geometry</i>	G.1	B
3	186	<i>The Number System</i>	NS.2	C
4	187	<i>Expressions and Equations</i>	EE.6	A
5	187	<i>Expressions and Equations</i>	EE.1	C
6	188	<i>Expressions and Equations</i>	EE.7	$x = 6$
7	189	<i>Ratios and Proportional Relationships</i>	RP.3	
8	190	<i>Expressions and Equations</i>	EE.5	D
9	190	<i>Geometry</i>	G.4	B
10	191	<i>The Number System</i>	NS.7	A
11	192	<i>Expressions and Equations</i>	EE.9	C
12	193	<i>Statistics and Probability</i>	SP.5	C
13	194	<i>Statistics and Probability</i>	SP.4	
14	195	<i>Expressions and Equations</i>	EE.1	C
15	195	<i>Expressions and Equations</i>	EE.3	B
16	195	<i>Expressions and Equations</i>	EE.5	D
17	195	<i>The Number System</i>	NS.1	A
18	196	<i>The Number System</i>	NS.5	5°F
19	196	<i>Geometry</i>	G.2	$\frac{1}{16}$ in. ³
20	197	<i>Ratios and Proportional Relationships</i>	RP.2	D
21	197	<i>Geometry</i>	G.1	A

* Answers are provided here for multiple-choice and short-answer items only. Sample responses and scoring guidelines for open-response items, which are indicated by the shaded cells, will be posted to the Department's website later this year.

Grade 6 Mathematics
Spring 2014 Unreleased Common Items:
Reporting Categories and Standards

Item No.	Reporting Category	Standard
22	<i>Geometry</i>	G.2
23	<i>Ratios and Proportional Relationships</i>	RP.3
24	<i>The Number System</i>	NS.4
25	<i>Geometry</i>	G.1
26	<i>Ratios and Proportional Relationships</i>	RP.1
27	<i>Expressions and Equations</i>	EE.2
28	<i>Statistics and Probability</i>	SP.4
29	<i>Expressions and Equations</i>	EE.3
30	<i>Statistics and Probability</i>	SP.4
31	<i>Ratios and Proportional Relationships</i>	RP.3
32	<i>Geometry</i>	G.1
33	<i>Ratios and Proportional Relationships</i>	RP.1
34	<i>Statistics and Probability</i>	SP.4
35	<i>Expressions and Equations</i>	EE.9
36	<i>Statistics and Probability</i>	SP.5
37	<i>The Number System</i>	NS.8
38	<i>Ratios and Proportional Relationships</i>	RP.3
39	<i>Geometry</i>	G.4
40	<i>Expressions and Equations</i>	EE.7
41	<i>Ratios and Proportional Relationships</i>	RP.1
42	<i>Expressions and Equations</i>	EE.9